



## Table of Contents

Introduction.....	3
Product Inspection .....	4
The EEE Test Adapter Care and Handling Precautions.....	5
General Test Adapter, Cable, and Connector.....	7
Handling and Storage .....	7
Visual Inspection .....	7
Cleaning.....	7
Making Connections.....	7
Electrostatic Discharge Information.....	8
Block Diagrams .....	9
Mechanical and Environmental Specifications.....	12
Electrical Specifications .....	14
Wilder Technologies, LLC – Limited Warranty .....	22
Wilder Technologies, LLC – Terms & Conditions of Sale .....	23
Compliance with Environmental Legislation .....	24
WEEE Compliance Statement.....	<b>Error! Bookmark not defined.</b>
Glossary of Terms .....	25
Index .....	26

## Introduction

This user's guide documents the Energy Efficient Ethernet Test Adapter (EEE-TPA-ER). The test adapter, shown in Figure 1, tests hosts to the requirements of the IEEE 802.3az specification. Design of the test adapter follows the EIA/TIA-568 standard with regard to pin/pair assignments and color coding of Ethernet cables.

The EEE-TPA-ER test adapter allows easy access, via RJ45, SMA, or probe access connections, for measuring or injecting data signals.

---

**NOTE: To avoid damaging the test adapter assembly, use the handling techniques described in the Care and Handling section before making any connections or configuring a test setup.**

**Always use a static-safe workstation when performing tests, as explained in the "Electrostatic Discharge Information" section.**

---

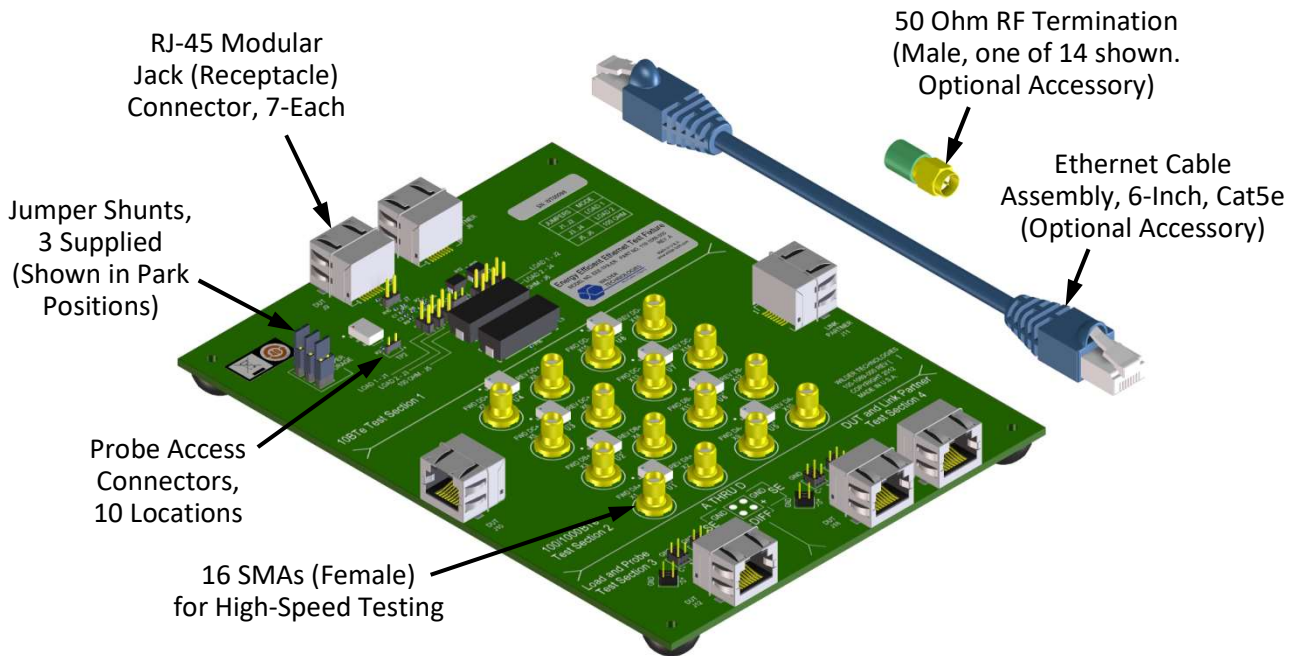

Figure 1. Energy Efficient Ethernet Test Adapter (Product name EEE-TPA-ER)  
(Note: Product name EEE-TPA-ERK includes RF Terminators and an Ethernet Cable)

---

**NOTE: The metal shell of each RJ-45 receptacle connector ties chassis ground to high-speed ground.**

---

### Product Inspection

Upon receiving the Energy Efficient Ethernet TPA from Wilder Technologies, perform the following product inspection:

- Inspect the outer shipping container, foam-lined instrument case, and product for damage. Retain the outer cardboard shipping container until the contents of the shipment have been inspected for completeness and the product has been checked mechanically and electrically. Use the foam-lined instrument case for secure storage of the Wilder Technologies Energy Efficient Ethernet Test Adapter when not in use.
- Locate the shipping list and verify that all items ordered were received.
- In the unlikely event that the product is defective or incomplete, the “Limited Warranty” section discusses how to contact Wilder Technologies for technical assistance and/or how to package the product for return.

### The EEE Test Adapter Care and Handling Precautions

The Energy Efficient Ethernet Test Adapter requires careful handling to avoid damage. Improper handling techniques, or using too small a cable bend radius, can damage the test instrument coaxial cables attached to the adapter SMA connectors, or can damage the Ethernet cables used during testing. This can occur at any point along a cable. To achieve optimum performance and to prolong the Energy Efficient Ethernet TPA's life, observe the following handling precautions:

- **CAUTION 1: Avoid Torque Forces (Twisting)**  
While individual test instrument or probe cables connected to the test adapter may have some rotational freedom, twisting the EEE test adapter as a unit, with cable or probe devices held stationary, may damage or severely degrade performance. Adherence to Caution 5 (below) helps to avoid twisting.
- **CAUTION 2: Avoid Sharp Cable Bends**  
Never bend cables greater than specified limits. Single or multiple cable bends should always be kept within specified limits. (See manufacturer's recommendations.) Bending connected cables beyond specified limits may permanently damage or severely degrade test connected cable performance.
- **CAUTION 3: Avoid Cable Tension (Pull Forces)**  
Never apply tension (pull forces) to an individual coaxial cable that is greater than 2.3 kg (5 lbs.). To avoid applying tension, always place accessories and equipment on a surface that allows adjustment to eliminate tension on the EEE TPA and cables. Use adjustable elevation stands or apparatus to accurately place and support the EEE TPA.
- **CAUTION 4: Connect to the Energy Efficient Ethernet TPA First**  
To prevent twisting, bending, or applying tension to test instrument cables or probe devices when connecting to an EEE TPA, always make attachments from the EEE TPA to the device under test (DUT) or cable under test and then attach any SMA connectors. Carefully align the RJ-45 connectors and then gently push the connectors together until fully seated.

If the EEE TPA must be turned or twisted to facilitate making connection to the DUT or test instrumentation, avoid using the EEE TPA alone to make this occur. Try to distribute the torque forces along the length of the test setup and cabling. If this is not possible, it is recommended to first loosen or disconnect any SMA connections at the EEE TPA, make the connection to the DUT and then re-tighten or attach the test equipment leads.

- **CAUTION 5: Carefully Make SMA Connections**

To connect the EEE TPA SMA connectors, follow these steps:

1. Hold the instrument coaxial cable stationary by grasping the cable near the SMA connector.
2. Insert the mating SMA barrel and hand-tighten the free-spinning SMA nut onto the EEE TPA SMA connector while avoiding pulling, bending, or twisting the test instrument coaxial cable.
3. Typically, the test instrument coaxial cable SMA connectors have flats that accept an open-end 5/16-inch wrench. When attaching instrument cables to the EEE TPA, it is recommended that the EEE TPA be firmly held and the test leads be tightened to the equipment manufacturer's torque recommendations, normally 5 in-lbs, using a 5/16-inch open-end torque wrench.

If the test set-up requires repositioning, first loosen or disconnect the SMA connections to avoid twisting, bending, or tension.

- **CAUTION 6: Independently Support Instrument Cables or Accessories**

Excessive weight from instrument cables and/or accessories connected to the EEE TPA can cause damage or affect the test adapter performance. Be sure to provide appropriate means to support and stabilize all test set-up components.

- **CAUTION 7: ESD Sensitivity**

The Energy Efficient Ethernet test adapter is a passive component and is not in itself sensitive to electrostatic discharge. However, when installed in an active DUT, that device becomes susceptible to ESD. Observe proper ESD precautions, further discussed later in this document.

### General Test Adapter, Cable, and Connector

Observing simple precautions can ensure accurate and reliable measurements.

#### Handling and Storage

Before each use of the EEE TPA, ensure that all connectors are clean. Handle all cables carefully and store the EEE TPA in the foam-lined instrument case when not in use, if possible. Do not set connectors contact end down. Install the SMA protective end caps when the EEE TPA is not in use.

#### Visual Inspection

Be sure to inspect all instrument cables, Ethernet cables, and device probes carefully before making a connection. Inspect all cables and connectors for metal particles, scratches, deformed threads, dents, or bent, broken, or misaligned center conductors. Do not use damaged cables.

#### Cleaning

If necessary, clean the connectors using low-pressure (less than 60 PSI) compressed air or nitrogen with an effective oil-vapor filter and condensation trap. Clean the cable threads, if necessary, using a lint-free swab or cleaning cloth moistened with isopropyl alcohol. Always completely dry a connector before use. Do not use abrasives to clean the connectors. Re-inspect connectors, making sure no particles or residue remains.

#### Making Connections

Before making any connections, review the “Care and Handling Precautions” section. Follow these guidelines when making connections:

- Align cables carefully
- Make preliminary connection lightly
- To tighten, turn connector nut only
- Do not apply bending force to cable
- Do not over-tighten preliminary connections
- Do not twist or screw-in cables
- When attaching instrumentation cables to the EEE test adapter, it is recommended that the test adapter be firmly held and that the instrument cable SMA connectors be tightened to the equipment manufacturer’s torque recommendations, normally 5 in-lbs, using a 5/16-inch open-end wrench. Do not tighten past the “break” point of the torque wrench.

## Electrostatic Discharge Information

Protection against electrostatic discharge (ESD) is essential while connecting, inspecting, or cleaning the EEE TPA test adapter and connectors attached to a static-sensitive circuit (such as those found in test sets).

Electrostatic discharge can damage or destroy electronic components. Be sure to perform all work on electronic assemblies at a static-safe work station, using two types of ESD protection:

- Conductive table-mat and wrist-strap combination
- Conductive floor-mat and heel-strap combination

When used together, both of these types provide a significant level of ESD protection. Used alone, the table-mat and wrist-strap combination provide adequate ESD protection. To ensure user safety, the static-safe accessories must provide at least 1 M $\Omega$  of isolation from ground. Acceptable ESD accessories may be purchased from a local supplier.

---

**WARNING: These techniques for a static-safe work station should not be used when working on circuitry with a voltage potential greater than 500 volts.**

---



This following example is a suggestion for testing with Section 2.

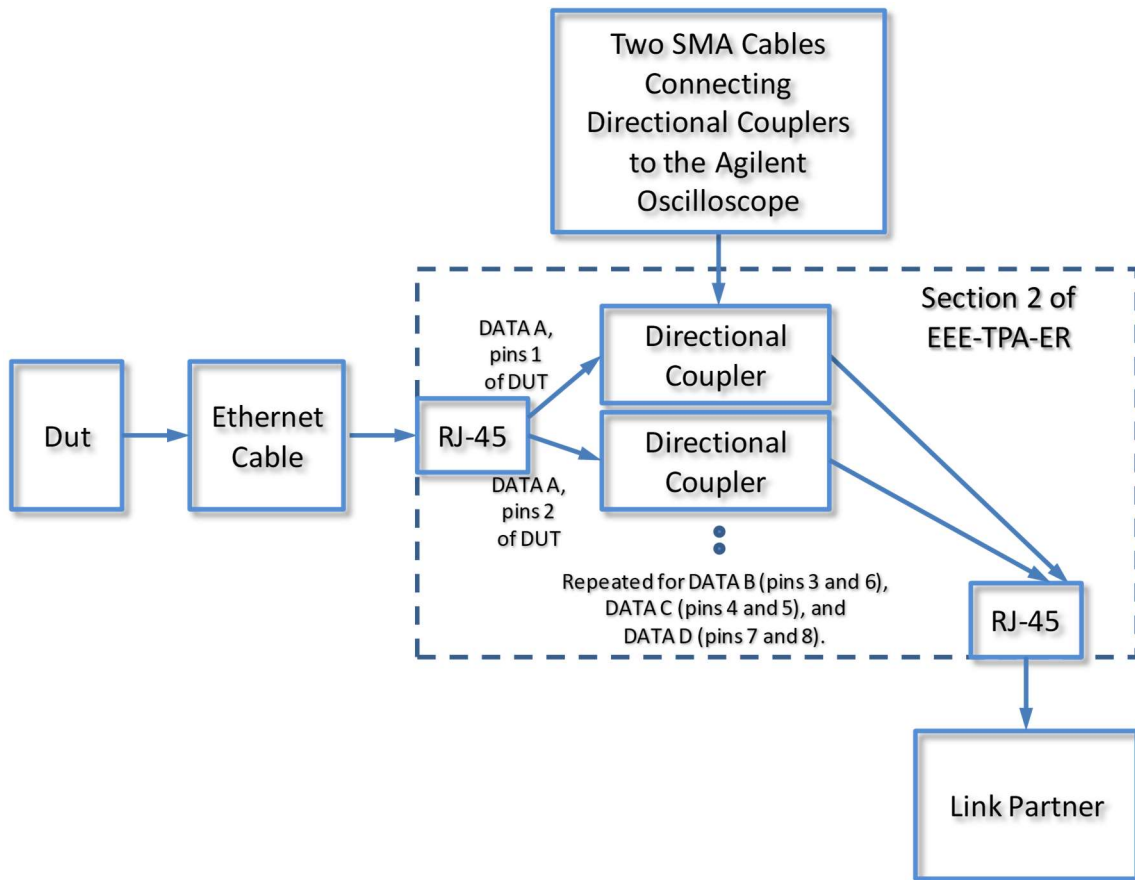

## Energy Efficient Ethernet Test Adapter User Manual

This following example is a suggestion for testing with Section 3.

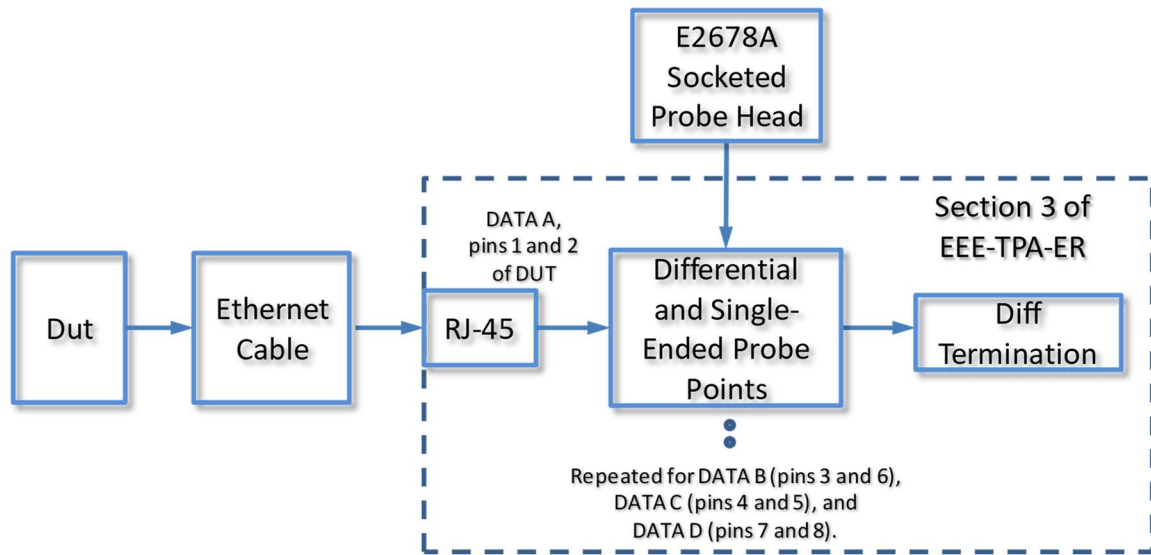

This following example is a suggestion for testing with Section 4.

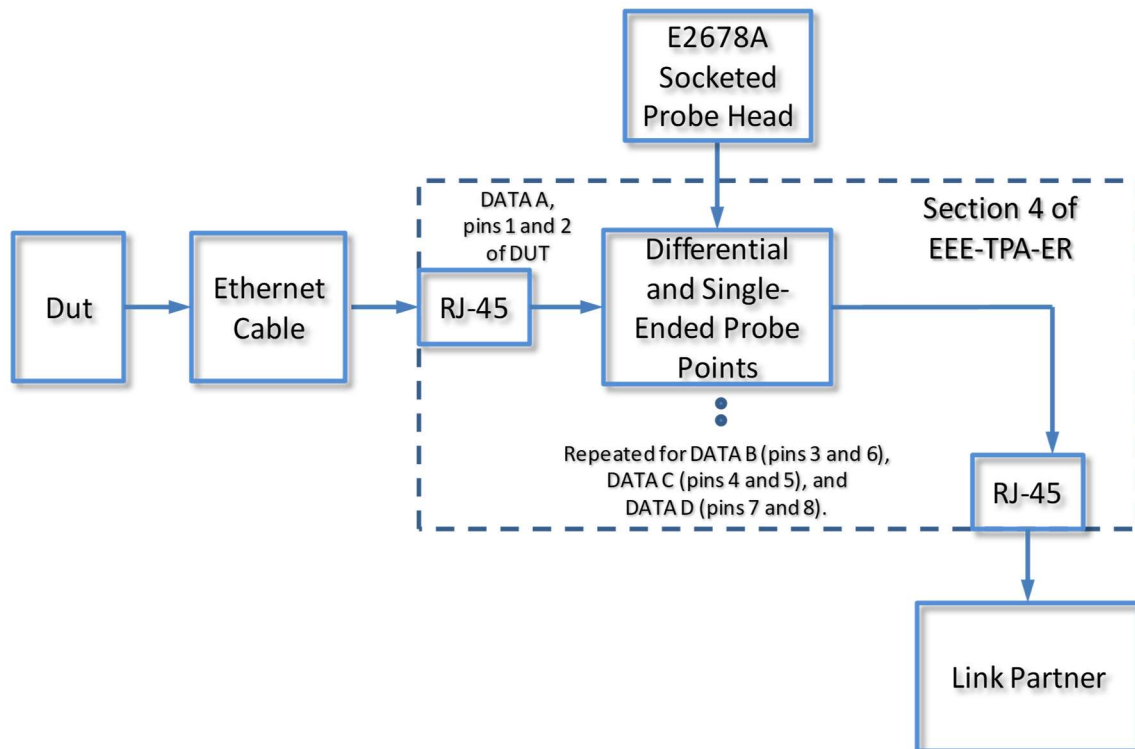

## Mechanical and Environmental Specifications

**NOTE: All specifications in this manual are subject to change.**

**Table 1. General Specifications**

ITEM	DESCRIPTION
Usage Environment	Controlled indoor environment
Test Adapter Dimensions (L, W, H)	184.15 x 139.70 x 24.13mm +/- 2 mm (7.50 x 5.5 x .90 inches +/- .08 inches) (Characteristic)
Operating Temperature	0°C to +55°C (32°F to +131°F) (Characteristic)
Storage Temperature	-40°C to +70°C (-40°F to +158°F) (Characteristic)

### EEE-TPA-ER Connector Pin-out (RJ-45)

The EEE-TPA provides 7 RJ-45 connectors and sixteen SMA connectors . A silk-screen legend clearly identifies each connector. The following figure refers to the pin-description table for the Rj-45 connectors (see table 2).

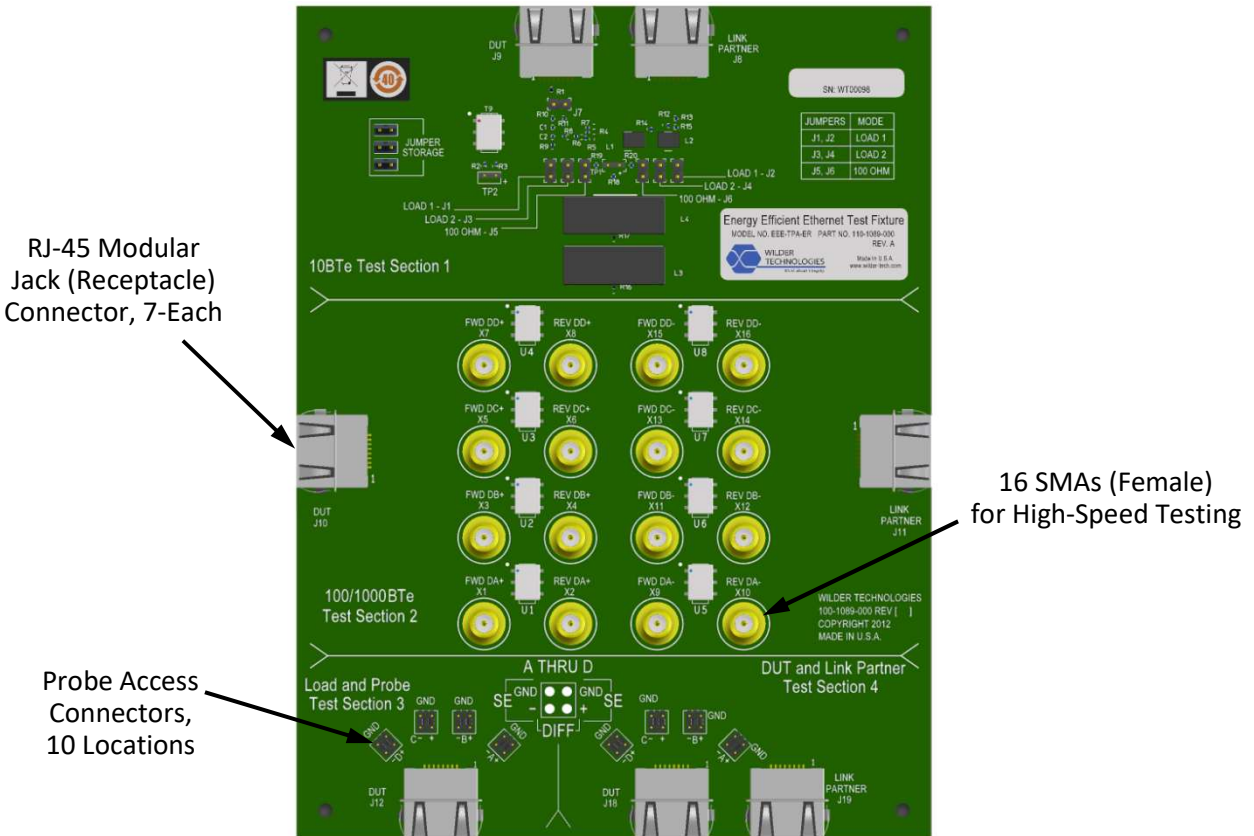
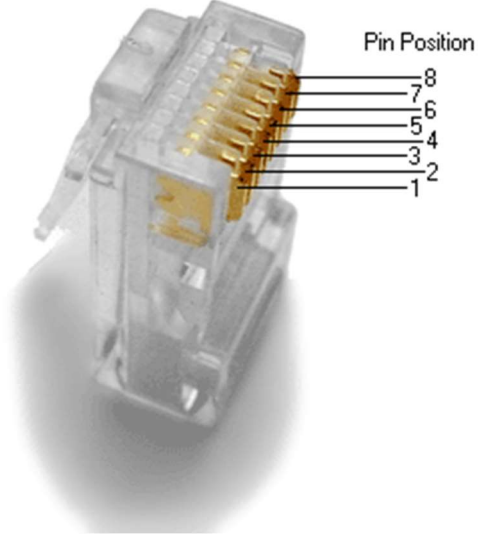









**Figure 2. TPA Connectors (EEE-TPA shown)**

## Energy Efficient Ethernet Test Adapter User Manual

**Table 2. RJ45 Connectors (High-Speed)**

The following figure refers to the pin/pair-description table for the EEE Test Adapter RJ-45 connectors.

Pin	T568A Pair	1000BASE-T Signal ID	Wire	T568A Color	Pins on plug face (socket is reversed)
1	3	DA+	tip	 white/green stripe	
2	3	DA-	ring	 green solid	
3	2	DB+	tip	 white/orange stripe	
4	1	DC+	ring	 blue solid	
5	1	DC-	tip	 white/blue stripe	
6	2	DB-	ring	 orange solid	
7	4	DD+	tip	 white/brown stripe	
8	4	DD-	ring	 brown solid	

## Electrical Specifications

**NOTE: All specifications in this manual are subject to change.**

**Table 3. Electrical Specifications (TPA)**

SPECIFICATION	MIN	TYP	MAX	NOTES
Differential Impedance (ohms), 100ps Rise Time, 20 – 80%	90		110	All Differential Pairs, Receptacle and Plug, excluding RJ-45, CAT-6 connector
Impedance (ohms), 100 ps Rise Time, 20 – 80%	45		55	Single-ended signals within differential pairs, Receptacle and Plug, excluding RJ-45, CAT-6 connector
Intra-pair Skew (ps)	-6		6	All Differential Pairs, Receptacle and Plug
Inter-pair Skew (ps)	-6		6	All Differential Pairs, Receptacle and Plug

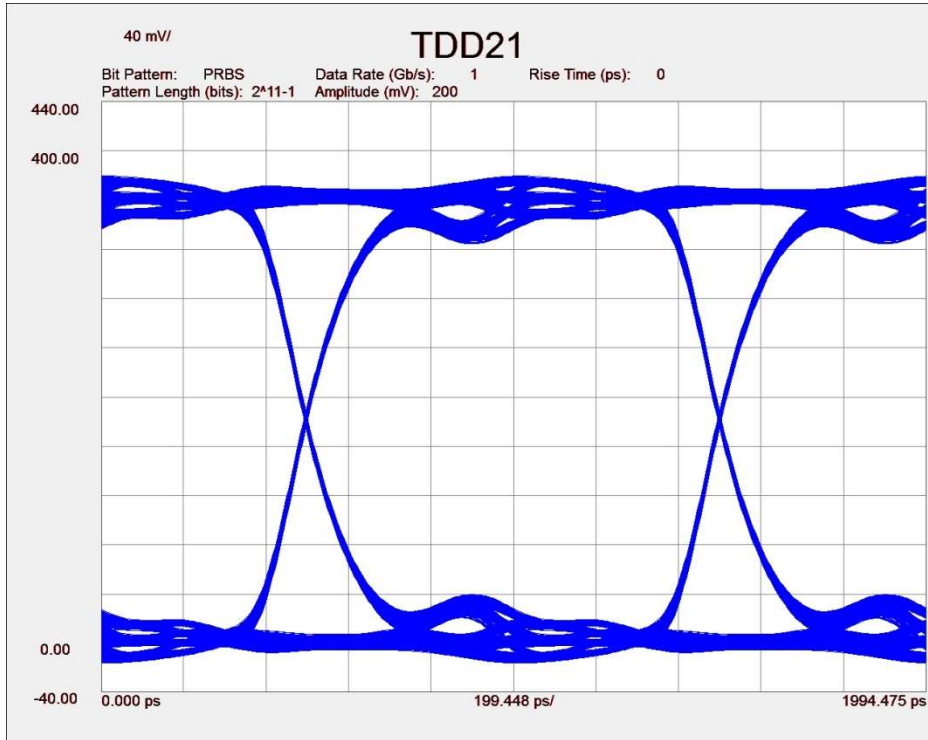

Figure 3. Typical mated pair 1 Gb/s eye diagram through section 2. (Measured with two ETH-TPA-RJ45 calibrated to the pads of the plugs.)

Parameter Measurement Result

Name	Measurement Result
Eye Level Zero(mV)	7.44
Eye Level One(mV)	356.59
Eye Level Mean(mV)	182.02
Eye Amplitude(mV)	349.15
Eye Height(mV)	293.08
Eye Height(db)	-5.33
Eye Width	9.80e-010
Eye Opening Factor	0.84
Eye Signal_to_Noise	14.44
Eye Duty Cycle Dist	-3.57e-013
Eye Duty Cycle Dist(%)	-0.04
Eye Rise Time (20-80)	1.64e-010
Eye Fall Time (80-20)	1.64e-010
Eye Jitter(PP)	2.00e-011
Eye Jitter(RMS)	3.15e-012

S<sub>11</sub> Param DUT Files Meas

Figure 4. Typical mated pair 1 Gb/s eye data through section 2. (Measured with two ETH-TPA-RJ45 calibrated to the pads of the plugs.)

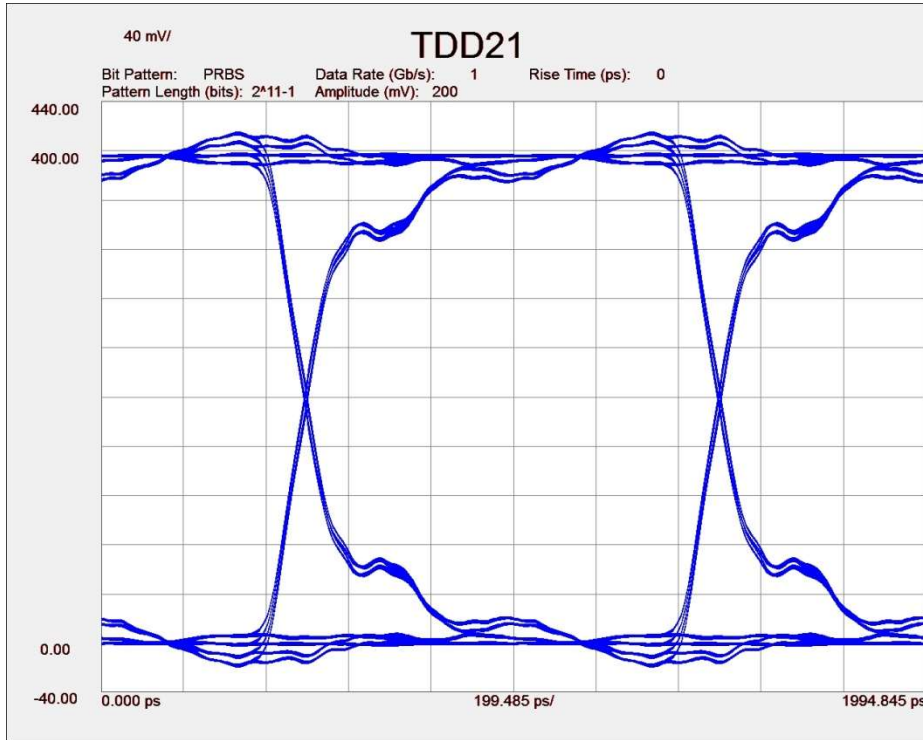

Figure 5. Typical mated pair 1 Gb/s eye diagram through section 4. (Measured with two ETH-TPA-RJ45 calibrated to the pads of the plugs.)

Parameter Measurement Result

Name	Measurement Result
Eye Level Zero(mV)	6.98
Eye Level One(mV)	389.08
Eye Level Mean(mV)	198.03
Eye Amplitude(mV)	382.10
Eye Height(mV)	348.41
Eye Height(db)	-4.58
Eye Width	9.80e-010
Eye Opening Factor	0.91
Eye Signal_to_Noise	26.02
Eye Duty Cycle Dist	-1.64e-013
Eye Duty Cycle Dist(%)	-0.02
Eye Rise Time (20-80)	1.31e-010
Eye Fall Time (80-20)	1.31e-010
Eye Jitter(PP)	2.00e-011
Eye Jitter(RMS)	3.87e-012

S Param DUT Files Meas

Figure 6. Typical mated pair 1 Gb/s eye data through section 4. (Measured with two ETH-TPA-RJ45 calibrated to the pads of the plugs.)

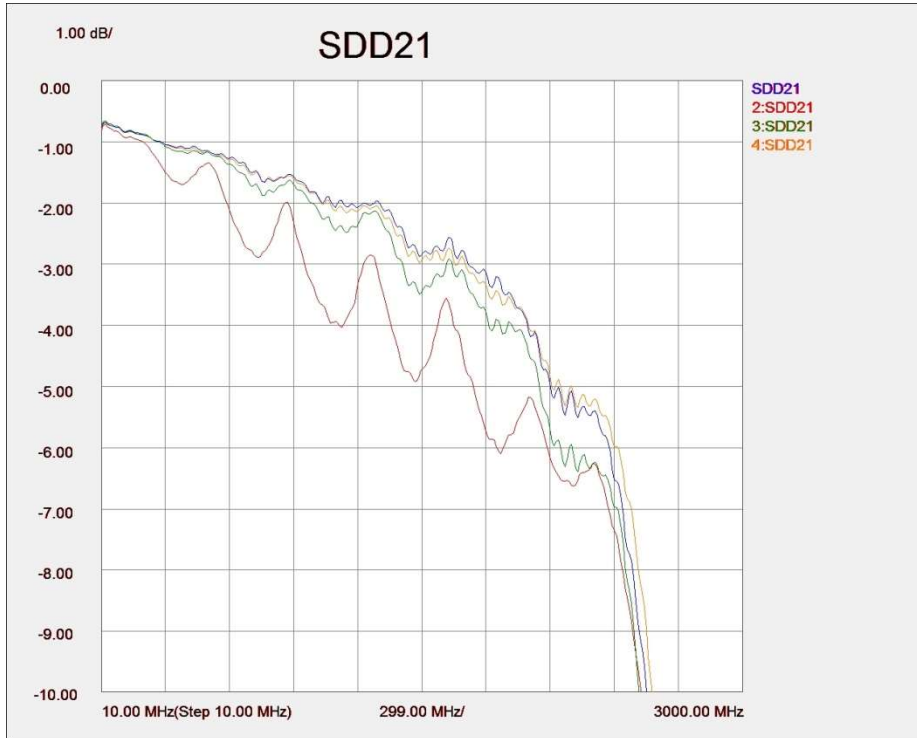

Figure 7. Typical section 2 balanced insertion loss. (Measured with two ETH-TPA-RJ45 calibrated to the pads of the plugs.)



Figure 8. Typical section 2 balanced insertion loss of coupler FWD output. (Measured with one ETH-TPA-RJ45.)

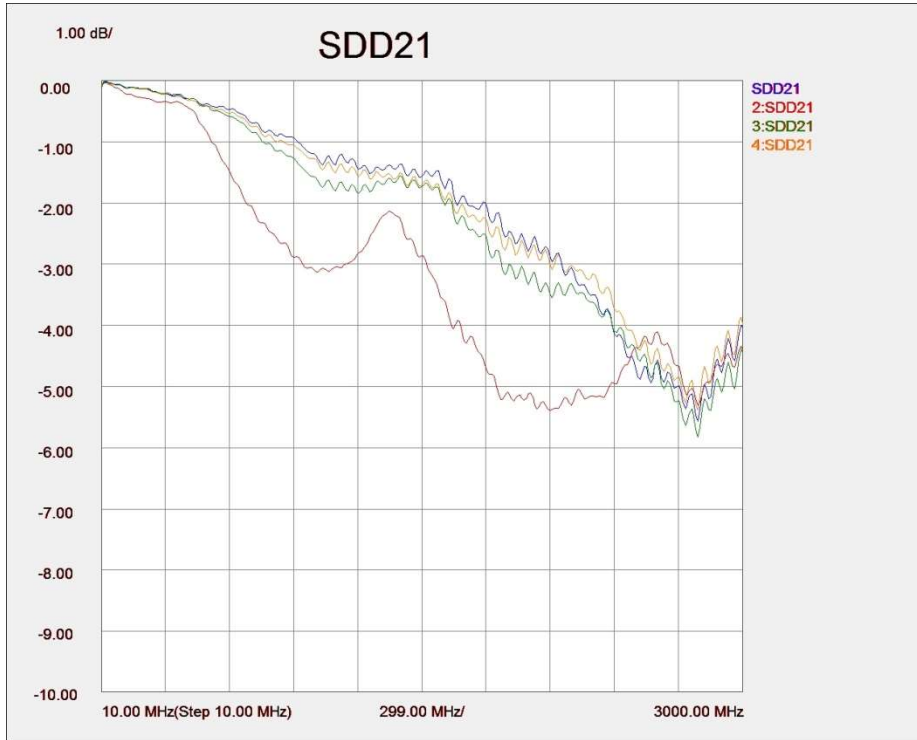

Figure 9. Typical section 4 balanced insertion loss. (Measured with two ETH-TPA-RJ45 calibrated to the pads of the plugs.)

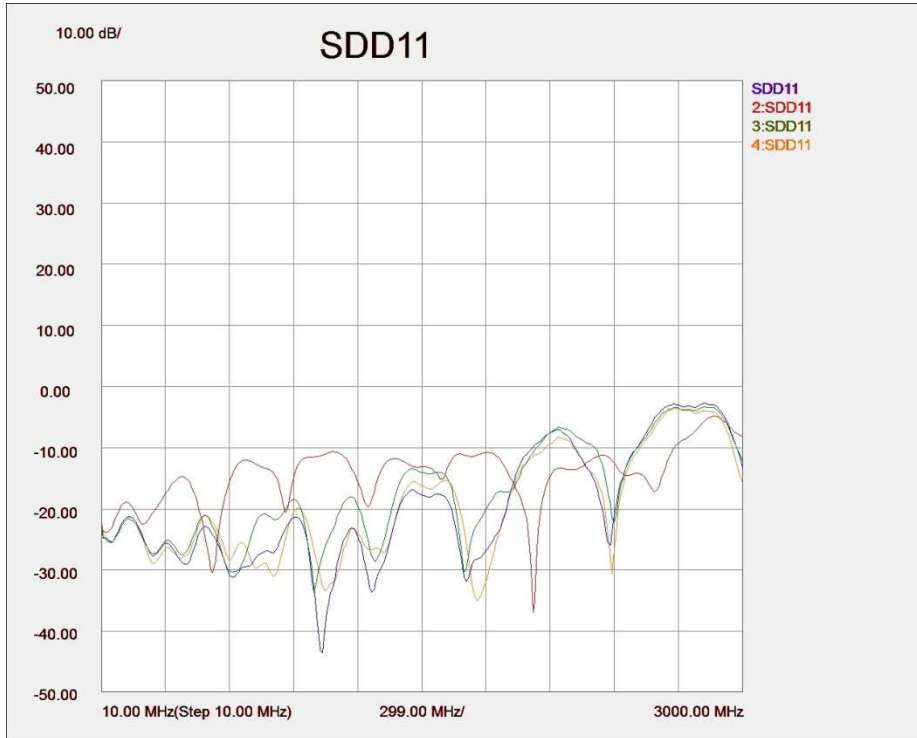

Figure 10. Typical section 2 balanced return loss. (Measured with two ETH-TPA-RJ45 calibrated to the pads of the plugs.)

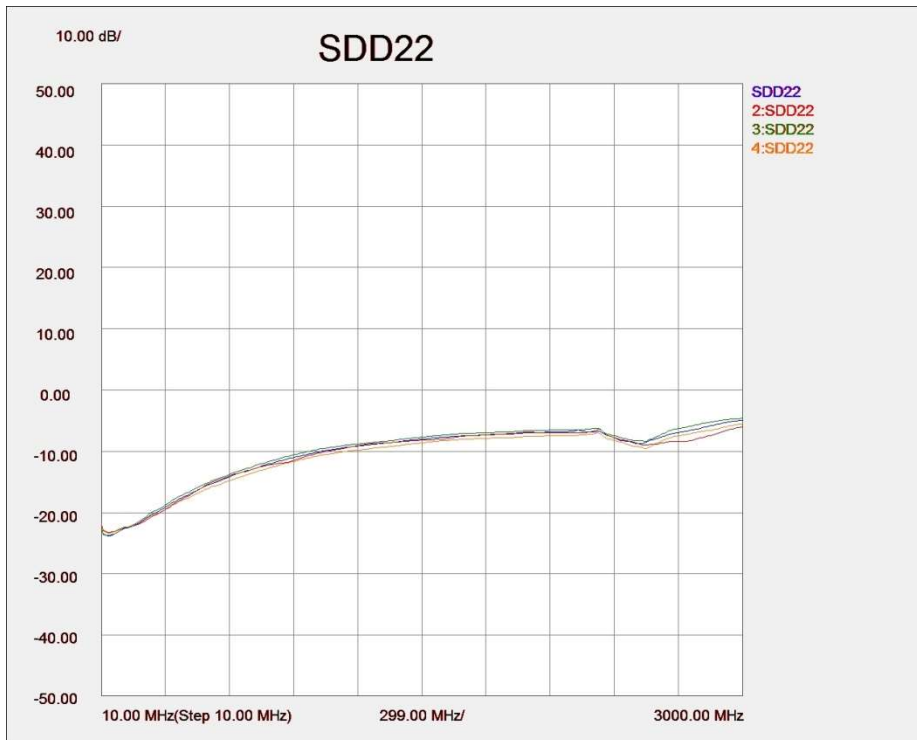

Figure 11. Typical section 2 balanced return loss of coupler FWD output. (Measured with one ETH-TPA-RJ45 at RJ-45 receptacle.)

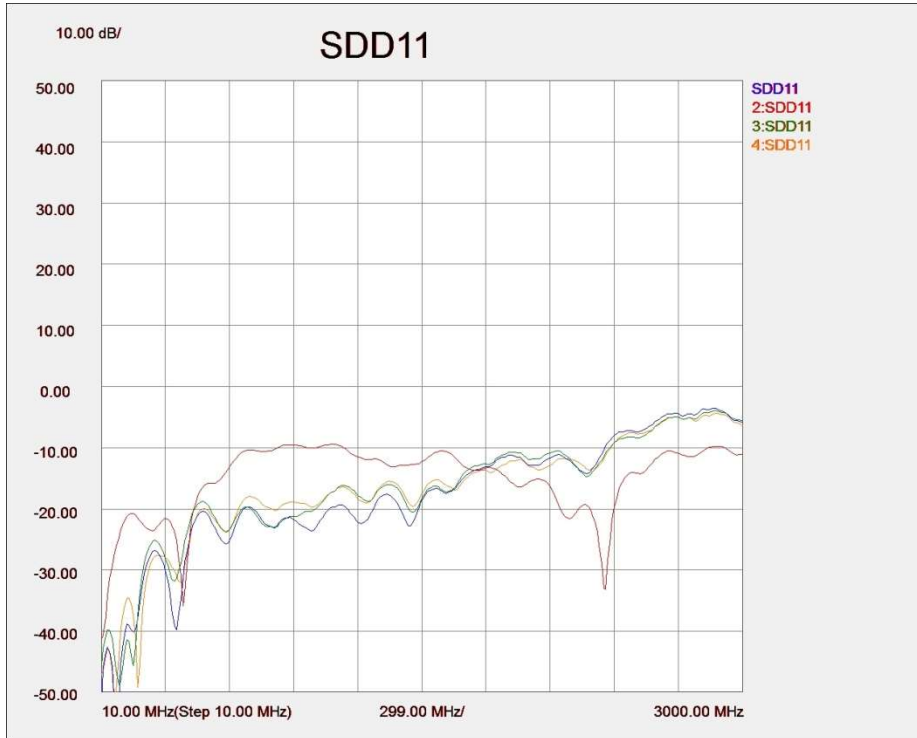

Figure 12. Typical section 4 balanced return loss. (Measured with two ETH-TPA-RJ45 calibrated to the pads of the plugs.)



Figure 13. Typical Differential NEXT for section 4, with mated connectors, adjacent differential pairs, both transmit and receive terminated at both ends. (Measured with two ETH-TPA-RJ45 calibrated to the pads of the plugs.)

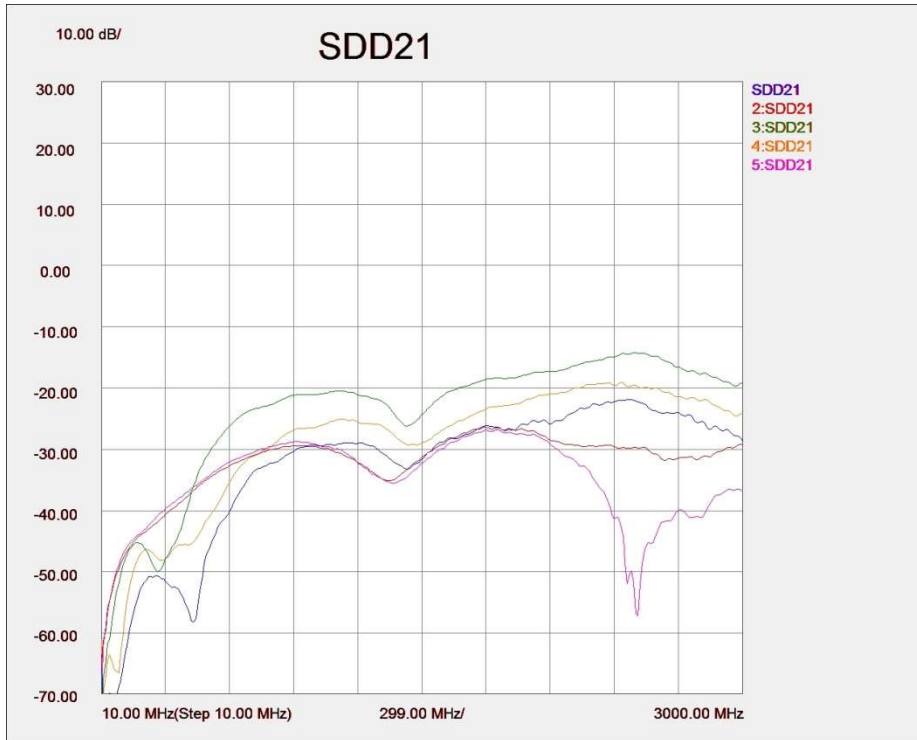

Figure 14. Typical Differential FEXT for section 4, with mated connectors, adjacent differential pairs, both transmit and receive terminated at both ends. (Measured with two ETH-TPA-RJ45 calibrated to the pads of the plugs.)

## Wilder Technologies, LLC – Limited Warranty

WILDER TECHNOLOGIES, LLC, warrants that the item(s) manufactured under the Buyer's contract shall be free from defects in materials and workmanship furnished by WILDER TECHNOLOGIES, LLC, and shall conform to the applicable drawings and specifications.

The warranty period for a Test Adapter is a specified, fixed period commencing on the date of ship from Wilder Technologies, LLC. If you did not purchase your Test Adapter directly from Wilder Technologies, LLC, the serial number and a valid proof of purchase will be required to establish your purchase date. If you do not have a valid proof of purchase, the warranty period will be measured from the date of ship from Wilder Technologies, LLC.

If, during the warranty period, the Test Adapter is not in good working order, Wilder Technologies, LLC will, at its option, repair or replace it at no additional charge, except as is set forth below. In some cases, the replacement Test Adapter may not be new and may have been previously installed. Regardless of the Test Adapter's production status, Wilder Technologies, LLC appropriate warranty terms apply.

### Consumable and Fragile Material Warranty

Wilder Technologies, LLC warrants that consumable materials and all fragile materials supplied by Wilder Technologies, LLC either as part of an instrument or system, or supplied separately, will be free from defects in material and workmanship at the time of shipment.

### Extent of Warranty

The warranty does not cover the repair or exchange of a Test Adapter resulting from misuse, accident, modification, unsuitable physical or operating environment, improper maintenance by you, or failure caused by a product for which Wilder Technologies, LLC is not responsible. The warranty is voided by removal or alteration of Test Adapter or parts identification labels. The initial three months are unconditional; the remaining months excludes plugs, receptacles and SMA connectors. Connectors are wear items and excluded from the warranty after the initial three months.

**These warranties are your exclusive warranties and replace all other warranties or conditions, express or implied, including but not limited to, the implied warranties or conditions of merchantability and fitness for a particular purpose. These warranties give you specific legal rights and you may also have other rights which vary from jurisdiction to jurisdiction. Some jurisdictions do not allow the exclusion or limitation of express or implied warranties, so the above exclusion or limitation may not apply to you. In that event, such warranties are limited in duration to the warranty period. No warranties apply after that period.**

### Items Not Covered by Warranty

Wilder Technologies, LLC does not warrant uninterrupted or error-free operation of a Test Adapter.

Any technical or other support provided for a Test Adapter under warranty, such as assistance via telephone with "how-to" questions and those regarding Test Adapter set-up and installation, will be provided **WITHOUT WARRANTIES OF ANY KIND**.

### Warranty Service

Warranty service may be obtained from Wilder Technologies, LLC by returning a Wilder Technologies, LLC Returns Material Authorization and the Test Adapter to Wilder Technologies, LLC during the warranty period. To obtain RMA number, contact [support@wilder-tech.com](mailto:support@wilder-tech.com).

You may be required to present proof of purchase or other similar proof of warranty entitlement. You are responsible for any associated transportation charges, duties and insurance between you and Wilder Technologies, LLC. In all instances, you must ship Test Adapters in Wilder Technologies, LLC approved packaging. Information on packaging guidelines can be found at: [www.wilder-tech.com](http://www.wilder-tech.com). Wilder Technologies, LLC will ship repaired or replacement Test Adapter Delivery Duty Prepaid (DDP) and will pay for return shipment. You will receive title to the repaired or replacement Test Adapter and you will be the importer of record.

## Wilder Technologies, LLC – Terms & Conditions of Sale

- 1. Other Documents:** This Agreement may NOT be altered, supplemented, or amended by the use of any other document(s) unless otherwise agreed to in a written agreement signed by both you and Wilder Technologies, LLC. If you do not receive an invoice or acknowledgement in the mail, via e-mail, or with your Product, information about your purchase may be obtained at [support@wilder-tech.com](mailto:support@wilder-tech.com) or by contacting your sales representative.
- 2. Payment Terms, Orders, Quotes, Interest:** Terms of payment are within Wilder Technologies, LLC's sole discretion, and unless otherwise agreed to by Wilder Technologies, LLC, payment must be received by Wilder Technologies, LLC prior to Wilder Technologies, LLC's acceptance of an order. Payment for the products will be made by credit card, wire transfer, or some other prearranged payment method unless credit terms have been agreed to by Wilder Technologies, LLC. Invoices are due and payable within the time period noted on your invoice, measured from the date of the invoice. Wilder Technologies, LLC may invoice parts of an order separately. Your order is subject to cancellation by Wilder Technologies, LLC, in Wilder Technologies, LLC's sole discretion. Unless you and Wilder Technologies, LLC have agreed to a different discount, Wilder Technologies, LLC's standard pricing policy for Wilder Technologies, LLC-branded systems, which includes hardware, software and services in one discounted price, allocates the discount off list price applicable to the service portion of the system to be equal to the overall calculated percentage discount off list price on the entire system. Wilder Technologies, LLC is not responsible for pricing, typographical, or other errors in any offer by Wilder Technologies, LLC and reserves the right to cancel any orders resulting from such errors.
- 3. Shipping Charges; Taxes; Title; Risk of Loss:** Shipping, handling, duties and tariffs are additional unless otherwise expressly indicated at the time of sale. Title to products passes from Wilder Technologies, LLC to Customer on shipment from Wilder Technologies, LLC's facility. Loss or damage that occurs during shipping by a carrier selected by Wilder Technologies, LLC is Wilder Technologies, LLC's responsibility. Loss or damage that occurs during shipping by a carrier selected by you is your responsibility. You must notify Wilder Technologies, LLC within 7 days of the date of your invoice or acknowledgement if you believe any part of your purchase is missing, wrong or damaged. Unless you provide Wilder Technologies, LLC with a valid and correct tax exemption certificate applicable to your purchase of Product and the Product ship-to location, you are responsible for sales and other taxes associated with the order. **Shipping dates are estimates only.**
- 4. WARRANTY:** WILDER TECHNOLOGIES, LLC, warrants that the item(s) manufactured under the Buyer's contract shall be free from defects in materials and workmanship furnished by WILDER TECHNOLOGIES, LLC, and shall conform to the applicable drawings and specifications. WILDER TECHNOLOGIES, LLC'S liability herein, for breach of warranty, contract or negligence in manufacturing, shall be limited to repair or replacement. Repair or replacement of defective items will be applicable only if the Buyer notifies WILDER TECHNOLOGIES, LLC, by written notice within 30-days of delivery. All claims shall be addressed to: [support@wilder-tech.com](mailto:support@wilder-tech.com) or WILDER TECHNOLOGIES, LLC, 6101A East 18th Street, Vancouver, Washington 98661 U.S.A.; ATTENTION: Customer Service Manager. WILDER TECHNOLOGIES, LLC, reserves the right to inspect at the Buyer's plant all items claimed to be defective or nonconforming prior to authorizing their return. WILDER TECHNOLOGIES, LLC, assumes no liability for the results of the use of its components in conjunction with other electric, electronic or mechanical components, circuits and/or systems. The foregoing constitutes the sole and exclusive remedy of the Buyer and the exclusive liability of WILDER TECHNOLOGIES, LLC, and is IN LIEU OF ANY AND ALL OTHER WARRANTIES, STATUTORY, IMPLIED OR EXPRESSED AS TO MERCHANTABILITY, FITNESS FOR THE PURPOSE SOLD, DESCRIPTION, QUALITY, and PRODUCTIVENESS OR ANY OTHER MATTER. Without limiting the foregoing, in no event shall WILDER TECHNOLOGIES, LLC, be liable for loss of use, profit or other collateral, or for special and/or consequential damages.
- 5. RETURNED GOODS:** WILDER TECHNOLOGIES, LLC, will accept only those goods for return that have been authorized for return. All goods authorized for return shall be assigned a Returned Material Authorization (RMA) Number. The RMA Number shall be clearly marked on the shipping container(s) and all documentation accompanying the goods authorized for return. The RMA Number shall be assigned by WILDER TECHNOLOGIES, LLC pursuant to the conditions set forth in Paragraph 4, WARRANTY.
- 6. UNITED STATES GOVERNMENT CONTRACTS:** In the event this offer is accepted under Government contract, WILDER TECHNOLOGIES, LLC, agrees to accept clauses required by Government regulations and to waive WILDER TECHNOLOGIES, LLC conditions inconsistent therewith. WILDER TECHNOLOGIES, LLC, certifies that it is a regular manufacturer or dealer of the goods and/or services offered herein and that the prices offered do not exceed those charged to any customer for like quantities, services or materials under the same conditions.

## Compliance with Environmental Legislation

Wilder Technologies, LLC, is dedicated to complying with the requirements of all applicable environmental legislation and regulations, including appropriate recycling and/or disposal of our products.



### WEEE Compliance Statement

The European Union adopted Directive 2002/96/EC on Waste Electrical and Electronic Equipment (WEEE), with requirements that went into effect August 13, 2005. WEEE is intended to reduce the disposal of waste from electrical and electronic equipment by establishing guidelines for prevention, reuse, recycling and recovery.

Wilder Technologies has practices and processes in place to conform to the requirements in this important Directive.

In support of our environmental goals, effective January 1<sup>st</sup>, 2009 Wilder Technologies, LLC has partnered with EG Metals Inc. – Metal and Electronics Recycling of Hillsboro, Oregon, [www.egmetalrecycling.com](http://www.egmetalrecycling.com), to recycle our obsolete and electronic waste in accordance with the European Union Directive 2002/96/EC on waste electrical and electronic equipment ("WEEE Directive").

As a service to our customers, Wilder Technologies is also available for managing the proper recycling and/or disposal of all Wilder Technologies products that have reached the end of their useful life. For further information and return instructions, contact [support@wilder-tech.com](mailto:support@wilder-tech.com).



### Compliance to RoHS 2 Substance Restrictions

Wilder Technologies, LLC certifies that the parts described in this document are compliant to the substance restrictions of Directive 2011/65/EU and Amendment Directive (EU) 2015/863 of the European Parliament, and of the Council of 8 June, 2011 and 31 March, 2015 on the restriction of the use of certain hazardous substances in electrical and electronic equipment (RoHS 2 Directive), prohibiting the use in homogeneous materials in excess of the listed maximum concentration value, except in cases where use is allowed by applicable exemptions listed in Annex III and Annex IV of the Directive.

Compliance with RoHS 2 has been verified through internal controls at design and production sites, including establishment of processes for specifying and controlling materials and segregation of non-compliant parts, receipt of supplier declarations of compliance and/or analytical test.

## Glossary of Terms

<b>TERMINOLOGY</b>	<b>DEFINITION</b>
Aggressor	A signal imposed on a system (i.e., cable assembly) to measure response on other signal carriers.
Decibel (dB)	Ten times the common logarithm (i.e. log10) of the ratio of relative powers.
Far-end crosstalk or FEXT	Crosstalk that is propagated in a disturbed channel in the same direction as the propagation of a signal in the aggressor channel. The terminals of the aggressor channel and the victim channel are usually close to each other.
Informative	The designation of a test that is not required for compliance.
Insertion loss	The ratio, expressed in dB, of incident power to delivered power.
Near-end crosstalk or NEXT	Crosstalk that is propagated in a disturbed channel in the opposite direction as the propagation of a signal in the aggressor channel. The terminals of the aggressor channel and the victim channel are usually close to each other.
Normative	The designation of a test that is required for compliance.
Return Loss	The ratio, expressed in dB, of incident power to reflected power.
RJ-45, CAT-6	For this manual. 8P8C modular connector system (8 positions 8 contacts) per TIA/EIA-568-A. Also Referred to in the industry as RJ-45.
RJ-45, CAT-6 TPA	RJ-45, CAT-6 Test Point Access. A specialized assembly that interfaces to a RJ-45, CAT-6 host or module and enables access of signals for measurement or stimulation.
Victim	A signal carrier on a system that has a response imposed on it by other signals in the system.

## Index

- Cable Bend Limits, 5
- Cable Tension (Pull Forces), 5
- Cable Twisting (Torque), 5
- Care and Handling, 5
- Cleaning, 7
- Compliance
  - RoHS, 24
  - WEEE, 24
- Connections
  - EEE TPA to DUT, 5
  - SMA, 6
- EEE-TPA-ER Connector Pinout, 12
- EIA/TIA-568 Standard, 3, 9
- Electrical Specifications, 14
- Electrostatic Discharge Information (ESD), 8
- ESD protection, 8
- ESD Sensitivity, 6
- Figures
  - The EEE-TPA-ER Test Adapter, 3
  - TPA Connectors, 12
- Glossary, 25
- Handling and Storage, 7
- IEEE 802.3az Specification, 3, 9
- Making Connections, 7
- Mechanical and Environmental Specifications, 12
- Product Inspection, 4
- Product Return, 4
- Pull Force, 5
- Secure Storage, 4
- SMA Connectors, 12
- Support, 23, 24
- Supporting Instrument Cables or Accessories, 6
- T568A Pin/Pair Assignments, 3
- Tables
  - Electrical Specifications (TPA), 14
  - General Specifications, 12
  - RJ-45 Connectors (High-Speed), 13
- Terms and Conditions of Sale, 23
- Visual Inspection, 7
- Warranty, 22
- Web Sites
  - support@wilder-tech.com, 22, 23, 24
  - www.egmetalrecycling.com, 24
  - www.wilder-tech.com, 22



Visit our website at [www.wilder-tech.com](http://www.wilder-tech.com)



**WILDER  
TECHNOLOGIES**

It's all about integrity

Wilder Technologies, LLC  
11201 NE 9<sup>th</sup> St.  
Vancouver WA, 98684  
Phone: 360-859-3041  
Fax: 360-859-3105  
[www.wilder-tech.com](http://www.wilder-tech.com)

©2024 Wilder Technologies, LLC  
Document No. 910-0027-000 Rev. D  
Created: 2/5/2013 Updated: 2/29/2024